

24" ADA-COMPLIANT SERIES WINE RESERVE

HA24WB-3 | 24" INDOOR MODEL

Perlick[®]
QUALITY & INNOVATION
THAT **INSPIRES**



Solid Door Model



Glass Door Model



Intertek

GENERAL 24" ADA-COMPLIANT SERIES FEATURES

- 32" height with leveling legs
- 525 Btu commercial-grade compressor
- Front-vented, RAPIDcool forced-air refrigeration system
- Commercial-grade stainless steel interior and black vinyl-clad exterior
- **Industry Exclusive** convertible door design allows all doors the ability to be converted to wood overlay from stainless steel
- **Industry Exclusive** adjustable, full-extension pull-out shelves
- Stainless-steel ball-bearing glides provide smooth movement of shelves
- Low E, UV-coated glass provides industry leading insulation and protection.
- Electromechanical temperature control
- Interior light
- Optional door locks and Industry-Exclusive drawer locks (factory installed)
- Stacking kit available
- Also available - ADA Compliant Freezer, Refrigerator, Beverage Center and 15" Clear Ice Maker
- 4.8 cubic feet of capacity
- Industry Best Three Year Warranty plus additional three years on sealed system

HA24WB-3 FEATURES

- Available with solid stainless steel door, wood overlay door, stainless steel glass door or wood overlay glass door
- Includes four (4) full-extension pull-out wine shelves to accommodate 32 bottles plus room for additional storage on the floor of the unit
- Shelves are removable and adjustable to accommodate oversize (magnum) bottles
- Wine Reserve temperature 45° - 65°F

Form No.HA24WB-3
Rev. 09.19.2014

PRODUCT SPECIFICATIONS

Overall Width	23-7/8" (60.64 cm.)
Overall Height	32" (81.28 cm.)
Overall Depth	24" (60.96 cm.)
Opening Width	24" (60.96 cm.)
Opening Height	32-1/8" (81.60 cm.)
Opening Depth	24" (60.96 cm.)
Refrigerated Volume	4.8 cu. ft total
Door Swing Clearance	25" (63.50 cm.)
Electrical	115V, 60Hz, 1 Phase, 2.3 amps
Plumbing	None Required
Shipping Weight	181 lbs (82.27 kg.)

INDOOR MODELS

- HA24WB-3-1L*** Solid stainless steel door, hinged left
- HA24WB-3-2L*** Solid wood overlay door, hinged left
- HA24WB-3-3L*** Stainless steel glass door
- HA24WB-3-4L*** Wood overlay glass door

*Also available with right hinge

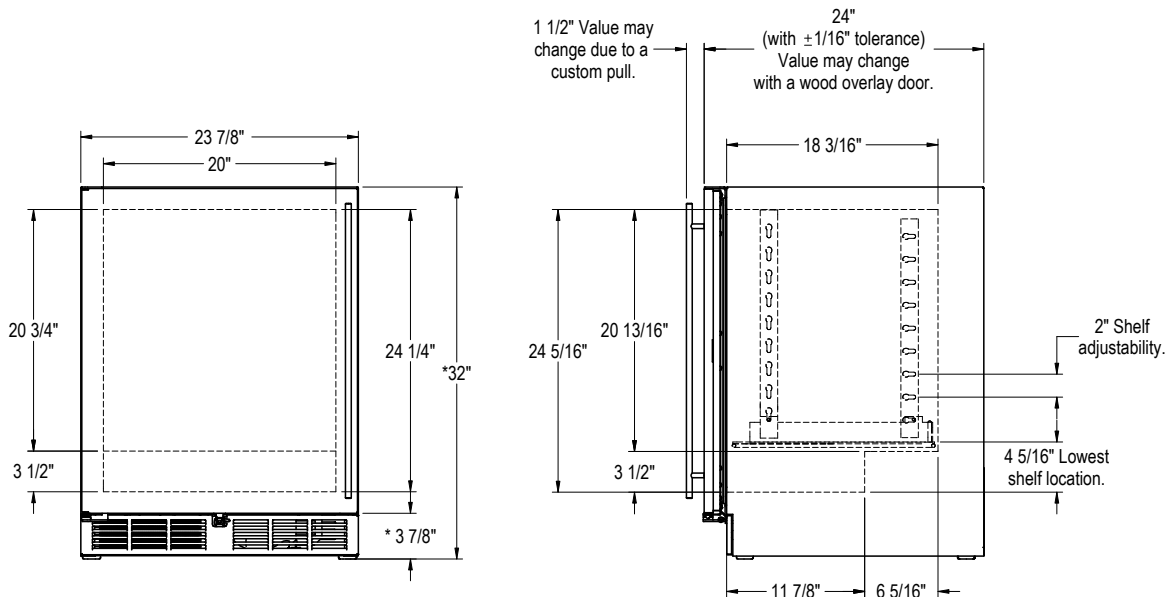
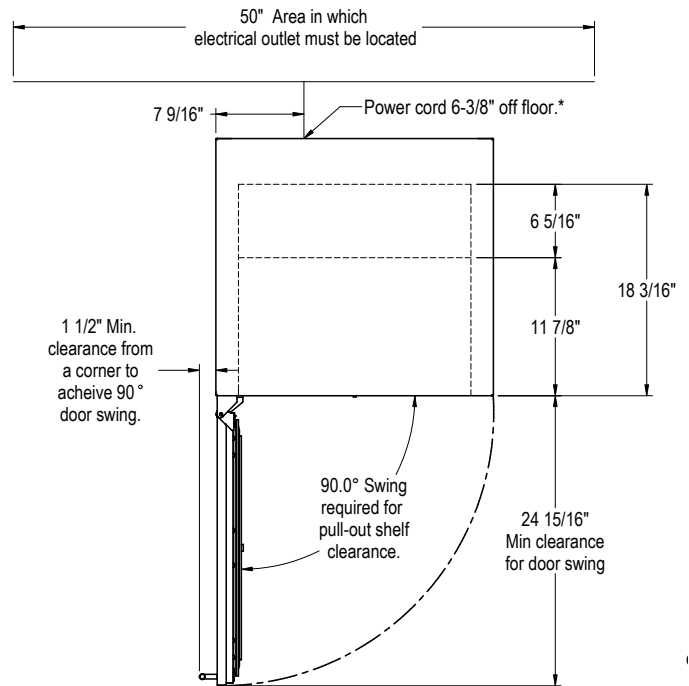

Form No.HA24WB-3
Rev. 09.19.2014