

BERTAZZONI MASTER SERIES

30" 4 INDUCTION ZONES, ELECTRIC SELF-CLEAN CONVECTION OVEN
MAS30 4 INS XT



Bertazzoni Master Series ranges blend commercial-kitchen style with Italian design. They are fully engineered for performance and designed with standard dimensions to work with existing kitchen layouts and units. The Master Series 30-inch induction range uses the most efficient heat-transfer technology for super-fast yet precise cooking. The beautiful smooth worktop includes 4 induction heating zones. Each zone is controlled with a dedicated knob, has variable power with boost function with a digital readout on the worktop, and a pan detection system. Residual heat indicators warn if a zone is still hot even when switched off, guaranteeing maximum safety. The extra large electric self-clean oven with European convection and 9 cooking modes ensures a balanced airflow and even heat distribution for single and multi-level roasting and baking with no flavor crossover. The oven includes telescopic glide shelves for easy operation. Complete your Bertazzoni range with any of the available ventilation and backsplash solutions, as well as low-profile back trim, toe kick and other beautiful accessories.

INDUCTION WORKTOP



The 4-zones induction worktop with variable heat and power boost function accommodates full-size cookware for super-fast yet precise cooking.

ELECTRIC CONVECTION OVEN

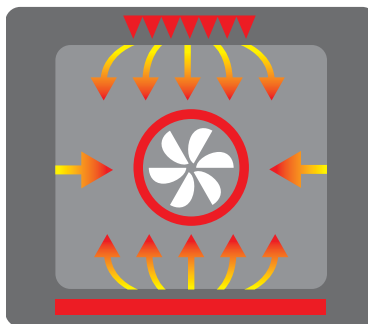

The extra-wide oven with heat-assisted convection fan and full-width broiler provides balanced air flow and even heat distribution.

TELESCOPIC GLIDE SHELVES



The telescopic oven rack provides more convenient oven access and easier handling of hot and heavy dishes.



TO COOK BEAUTIFULLY

BERTAZZONI MASTER SERIES

30" 4 INDUCTION ZONES, ELECTRIC SELF-CLEAN CONVECTION OVEN - MAS30 4 INS XT

FEATURES

Induction Zones	4
Worktop	induction
Worktop Controls	knobs
Residual Heat Indicator	yes
Knobs	soft touch
Backguard	standard 4 inches
Front Left	7"-1850 W (Booster 3000 W)
Back Left	7"-1850 W (Booster 3000 W)
Front Right	5" 3/4"-1400 W (Booster 2200 W)
Back Right	8" 1/2"-2300 W (Booster 3700 W)
Main oven	electric convection self-clean with electric broiler
Main oven functions	convection, bake, convection bake, turbo convection, convection broil, defrost/dehydrate, proofing, warming, broil, self clean
Main oven volume	3.4 ft ³
Inner oven door	quadruple glass
Oven equipment	1 telescopic glide shelf, 1 baking tray, 2 heavy gauge wire shelves, 1 grill trivet for tray
Legs	height adjustable stainless steel wrapped legs

TECHNICAL SPECIFICATIONS

Voltage, frequency	120/208 V - 120/240 V, 60Hz
Max Amp Usage, power rating	53 A - 11800 W, 56 A - 12900 W Specified Rating of Power Supply Cord Kit and Circuit Protection
Rating*	208/240 Volts 120/208 Volts Amps: 50 A
Certification	CSA
Warranty	2 years parts and labor

*The National Electric Code calculation for Electric Load is less than the Total Connected Electrical Load listed on the model rating plate.

ACCESSORIES

Toe kick panel (TKS 30 X), flat island trim (IRF 30 X), side trim (ST 36X)

MATCHING VENTILATION SOLUTIONS

Bertazzoni offers a variety of matching ventilation solutions for this range. Please check our website under the ventilation tab for a complete overview of all choices

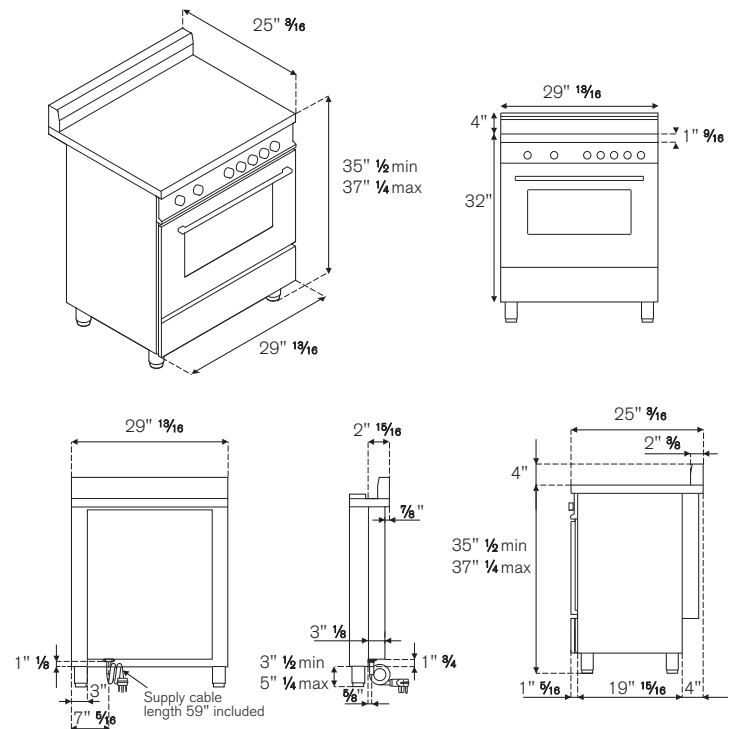

INSTALLATION INSTRUCTIONS

Bertazzoni recommends to operate the appliance after it has been installed in a cabinet. The kitchen cabinets shall be made of materials capable of withstanding temperatures at least 117°F (65°C) above room temperature in order to avoid possible damage to the cabinets during oven usage. For further installation instructions refer to the installation manual.

Disclaimer: while every effort has been made to insure the accuracy of the information contained in this brochure, Fratelli Bertazzoni reserves the right to change any part of the information at any time without notice.

Fratelli Bertazzoni, Bertazzoni and the winged wheel brand icon are registered trademarks of Bertazzoni Spa.