

VentAhood®

CHARLESTON WALL-MOUNT RANGE HOOD



PREMIUM STAINLESS STEEL HOOD

comes with satin brass lip treatment on all sides and a pair of 2" vertical bands in satin brass attached with laminate.

AVAILABLE MODELS

JDH/SB Model	Width	CFM
JDH236/C2-SS/AS-SB	36"	600
JDH348/C2-SS/AS-SB	48"	900

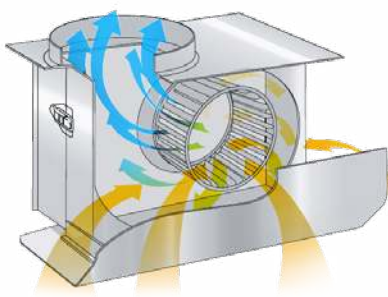

QUIET AND POWERFUL

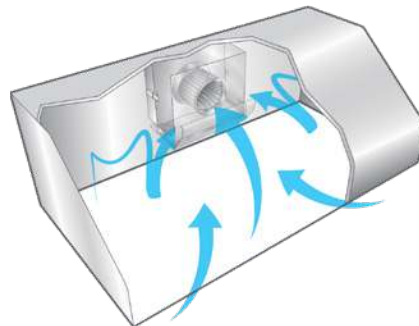

EFFICIENT



LIFETIME WARRANTY



PINNACLE
SALES GROUP

P: 800-292-8374 • F: 800-574-8805
www.pinnaclesalesgroup.com

VentAhood®

CHARLESTON WALL-MOUNT RANGE HOOD

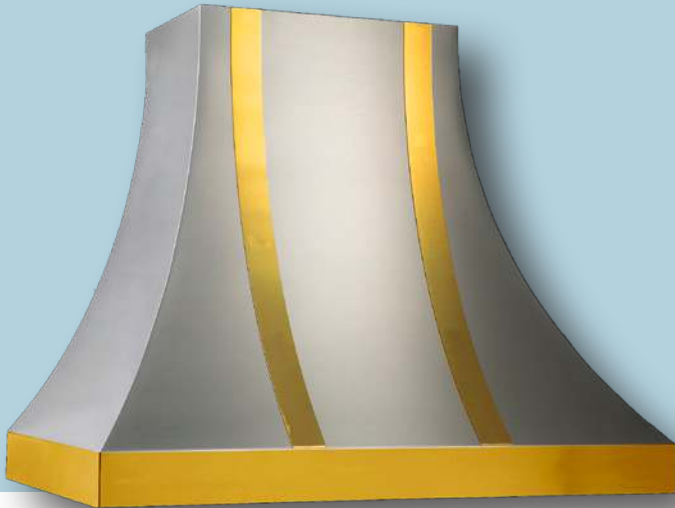

AVAILABLE MODELS

JDH/SB Model	Width	CFM	Duct
JDH236/C2-SS/AS-SB	36"	600	6"
JDH348/C2-SS/AS-SB	48"	900	8"

DUCT COVERS

Model	Width	Height	CLG.
WDCRND-18/12/JDH/C2/AS-SB	18"	12"	9'
WDCRND-18/24/JDH/C2/AS-SB	18"	24"	10'
WDCRND-30/12/JDH/C2/AS-SB	30"	12"	9'
WDCRND-30/24/JDH/C2/AS-SB	30"	24"	10'

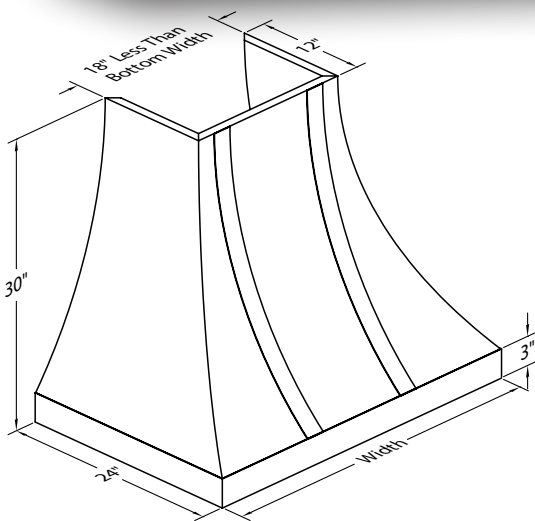

CONNECTION DIAGRAM

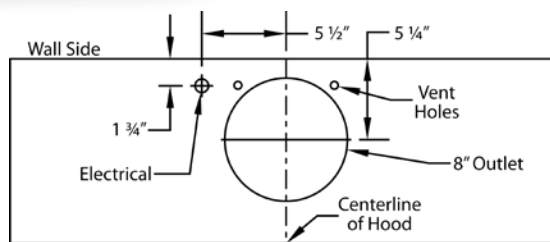

600 CFM B200 Dual Blower (Top View)

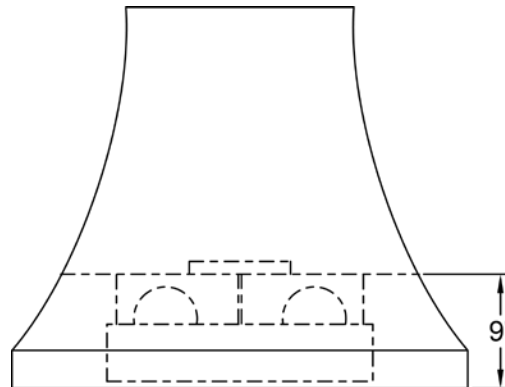

(Front View)

RECOMMENDED MOUNTING HEIGHT

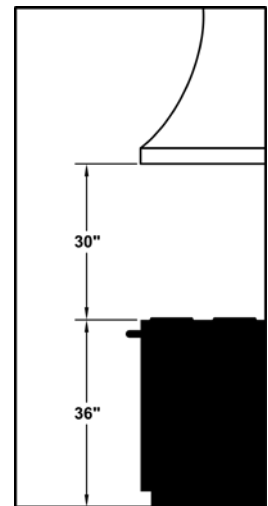

*Exceeding recommended mounting height may compromise performance.

ELECTRICAL/MECHANICAL SPECIFICATIONS FOR BLOWER UNIT

Model	Volts	Amps+	Hz	RPM	CFM SP@0.0"	Equiv. CFM\$	CFM SP@0.1"	CFM SP@0.2"	CFM SP@0.3"	Minimum Round Duct Size (50 sq. in.)	Sones#
B200 Dual	115	4.0	60	1550	600	900	531	480	430	8"	6.5

+ This model is equipped with LED lighting: (2 lights: 30" - 41", 3 lights: 42" - 53", 4 lights: 54" - 66").

\$ Because the Magic Lung® blower uses centrifugal filtration rather than conventional baffle or mesh filters, the Magic Lung® blower can handle cooking equipment with higher cubic feet per minute (CFM) requirements and can deliver equivalent CFM much more efficiently than other filtration systems. When comparing the Magic Lung® with other blower units made by other manufacturers, use the "Equivalent CFM".

Ratings in accordance with the Standard Test Code by the Energy Systems Laboratory of the Texas Engineering Experiment Station. This specification sheet is subject to change without notice.

