

VentAhood®

# NAPA WALL-MOUNT RANGE HOOD



## PREMIUM STAINLESS STEEL HOOD

comes with (4) 1" vertical bands in mirrored stainless steel attached with ¼" rivets and mirrored stainless steel on clips.

## AVAILABLE MODELS

XRH18 Model	Width	CFM
XRH18-236-SS/AS	36"	600
XRH18-348-SS/AS	48"	900

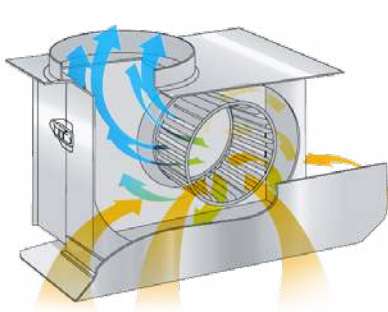

QUIET AND POWERFUL

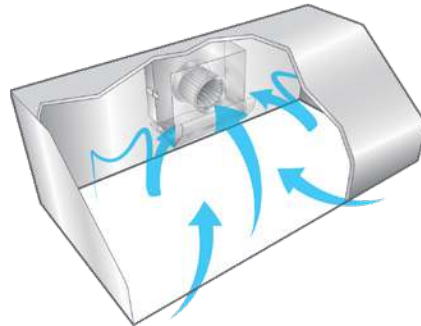

EFFICIENT



LIFETIME WARRANTY



P: 800-292-8374 • F: 800-574-8805  
www.pinnaclesalesgroup.com

VentAhood®

# NAPA WALL-MOUNT RANGE HOOD

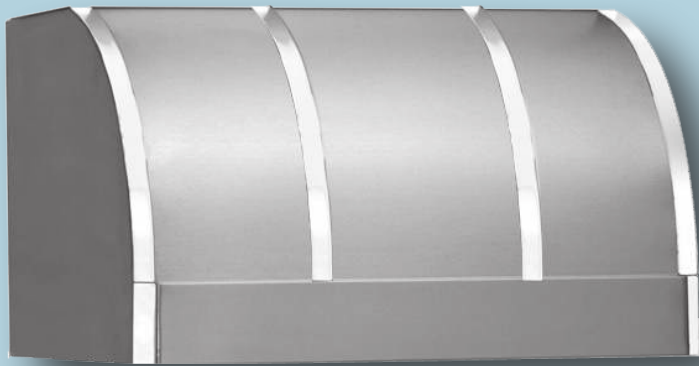

## AVAILABLE MODELS

XRH18 Model	Width	CFM	Duct
XRH18-236-SS/AS	36"	600	8"
XRH18-348-SS/AS	48"	900	6" & 8"

## DUCT COVERS\*

Model	Width	Height	CLG.
WDCRND-36 SS	36"	12"	8'
WDCRND-36/24 SS	36"	24"	9'
WDCRND-48 SS	48"	12"	8'
WDCRND-48/24 SS	48"	24"	9'
WDCRND-48/36 SS	48"	36"	10'

\*Duct cover comes in a stainless steel finish without bands.

## RECOMMENDED MOUNTING HEIGHT

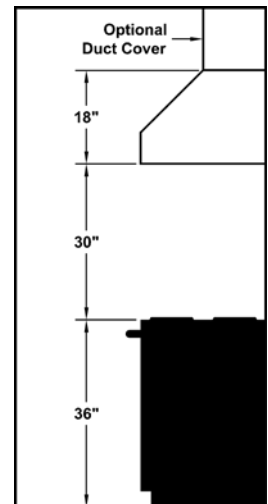

\*Exceeding recommended mounting height may compromise performance.

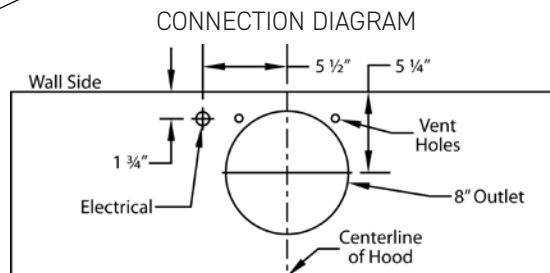
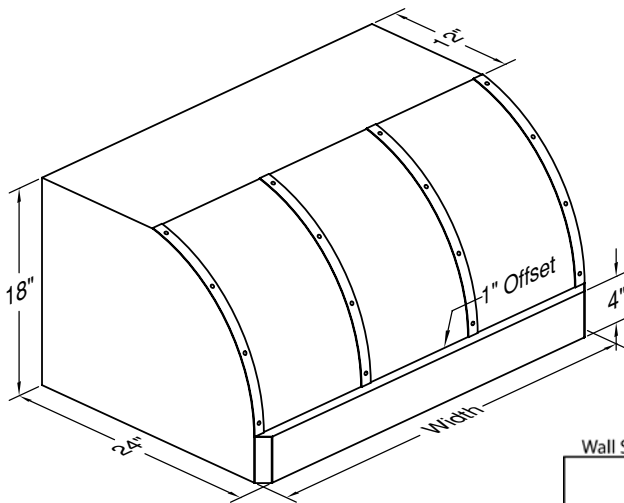

600 CFM B200 Dual Blower (Top View)

## ELECTRICAL/MECHANICAL SPECIFICATIONS FOR BLOWER UNIT

Model	Volts	Amps+	Hz	RPM	CFM SP@0.0"	Equiv. CFM\$	CFM SP@0.1"	CFM SP@0.2"	CFM SP@0.3"	Minimum Round Duct Size (50 sq. in.)	Sones#
B200 Dual	115	4.0	60	1550	600	900	531	480	430	8"	6.5

+ This model is equipped with LED lighting: (2 lights: 30" - 41", 3 lights: 42" - 53", 4 lights: 54" - 66").

\$ Because the Magic Lung® blower uses centrifugal filtration rather than conventional baffle or mesh filters, the Magic Lung® blower can handle cooking equipment with higher cubic feet per minute (CFM) requirements and can deliver equivalent CFM much more efficiently than other filtration systems. When comparing the Magic Lung® with other blower units made by other manufacturers, use the "Equivalent CFM".

# Ratings in accordance with the Standard Test Code by the Energy Systems Laboratory of the Texas Engineering Experiment Station. This specification sheet is subject to change without notice.

